

# SHARP

MX-M1205 / MX-M1055  
Production Print System



HIGH PERFORMANCE SRA3  
BLACK AND WHITE PRINTING



We understand the pressure of deadlines /**This is Why** our print systems offer productivity and cost efficiency as standard.

## We understand print room pressure /This is Why we bring you total productivity.

Introducing the MX-M1205 and the MX-M1055: two powerful production print systems delivering end-to-end efficiency for maximum productivity and lower operating costs.

Packed with features that will be appreciated by expert and inexperienced operators alike, they're a great choice for busy print rooms and corporate reprographic departments.

Building on our award winning print solutions that include industry-first touchscreen characteristics, each of these machines feature our first-class integral print server that's controlled through touchscreen input. Every feature for every job and every setting can be adjusted through familiar fingerswipe gestures such as tap, flick, slide, drag and long touch.

Workflows, job management, media control and advanced print settings are all within easy reach for the ultimate in print room productivity.

### Experience total control with our one-touch Fiery gateway

Not only are both machines equipped with Sharp's advanced production print technology as standard, but they also integrate with industry-leading EFI Fiery Digital Front End print servers. Simply specify the very latest model as an option.

Our unique Fiery gateway mode will give you convenient one-touch access to EFI's market-leading Command WorkStation, with no need to sacrifice space with an additional workstation. Simply touch the dedicated Fiery key to toggle between Command WorkStation and Sharp's fully-featured native user interface.

In Fiery gateway mode, any jobs coming into Command WorkStation - and any machine or media adjustments that you want to make - can be handled directly from the control panel. There's no clutter and no fuss - just instant and effortless control from start to finish.





## Superior control, effortless efficiency. /This is Why every print room needs our black & white production print systems.

Engineered for fast and cost-efficient, high-volume printing, copying and scanning, the MX-M1205 and the MX-M1055 leverage the power of Sharp's production print control technology to satisfy the demands of even the busiest print rooms.

Advanced print settings make it easy for the operator to manage paper properties, optimising the processing of special and custom paper media and reducing job interruptions. Plus, job management is quick and efficient thanks to easy, intuitive controls, and a range of advanced settings bring simplicity to the most complex operations, even on special media.

They're designed for convenience, too. The large 15.4" control panel swings out, tilts and swivels for optimum comfort, making it easy to view and edit jobs before printing, reducing errors and improving efficiency. The user interface can also be displayed on a remotely connected PC or networked display unit for comfortable operation and convenient technical support.

For even greater ease of use, the control panel is fully customisable. Users can create their own home pages complete with unique backgrounds and shortcuts to their favourite and most frequently used features, making control fast and efficient. A keyboard and touchpad are also available as an option.

For seamless efficiency and low operating costs - on their own or integrated with the wider print room environment - the MX-M1205 and MX-M1055 win every time.

FULL SIZE  
KEYBOARD &  
TOUCHPAD

ONE-TOUCH FIERY  
GATEWAY KEY



FULLY ADJUSTABLE  
TOUCHSCREEN



## Downtime is expensive /This is Why our printers are designed for sustained productivity.

Even with non-urgent deadlines, every manual intervention costs time and reduces productivity. That's why Sharp's engineering and design teams have done everything they can to keep your print volumes at maximum, helping you to optimise the return on your investment in our print room technology.

The raw power of these machines is enhanced by fast warm-up times, a rapid first copy out time, a paper capacity that can grow to 13,500 sheets and continuous printing, even when replenishing the paper or toner.

Stock up to 300 gsm in weight, and SRA3 in size, is smoothly handled from large capacity and bypass trays for a wider variety of professionally finished corporate documents.

### Stop less. Do more.

One look at the rigid frame and quality construction of the MX-M1205 and the MX-M1055 will tell you that these machines are built for high-performance, high-volume printing with minimum downtime. But it doesn't stop there.

Our triple air-feed system brings significant advantages over conventional roller feed systems, by eliminating the need to change rollers. This prevents jams and multi-feeds, improving reliability when working with a variety of stock.

Multi-feed detection, and smart ultrasonic detection of multiple feeds and misfeeds in the document feeder and paper feed sections also help to prevent delays and maintain efficiency.

### MID-PRINT CONSUMABLE REPLENISHMENT



### FULL FRONT ACCESS





## No one wants to waste time reading manuals /This is Why we make our production printers easy to use.

The MX-M1205 and the MX-M1055 are designed for maximum productivity and effortless ease of use. Greater ease of use means fewer errors. And fewer errors means lower cost of ownership. Here's how we do it.

### Long unattended print runs

No one wants to spend the day keeping one eye on the printer. So most of our customers specify the optional Status Lamp, mounted on a mast that can be seen across the room. A quick glance will show operators a green lamp, confirming that everything is OK, or a red lamp if intervention is required.

### Easy access for rapid intervention

Every minute spent attending to the printer is a minute lost. So with Sharp you'll find that all of the routine maintenance areas can be easily accessed from the front of the device, reducing the time it takes to clear paper jams or change toner.

### Convenient workflows

Both machines are ready to run Sharpdesk Mobile, our mobile printing and scanning application, and any of a growing number of productivity apps that run under Sharp OSA (Open System Architecture).

A conveniently located USB port is also included, to facilitate walk up printing and scanning in a useful variety of common file formats, and the optional Web Expansion Kit lets you perform web searches directly from the control panel.

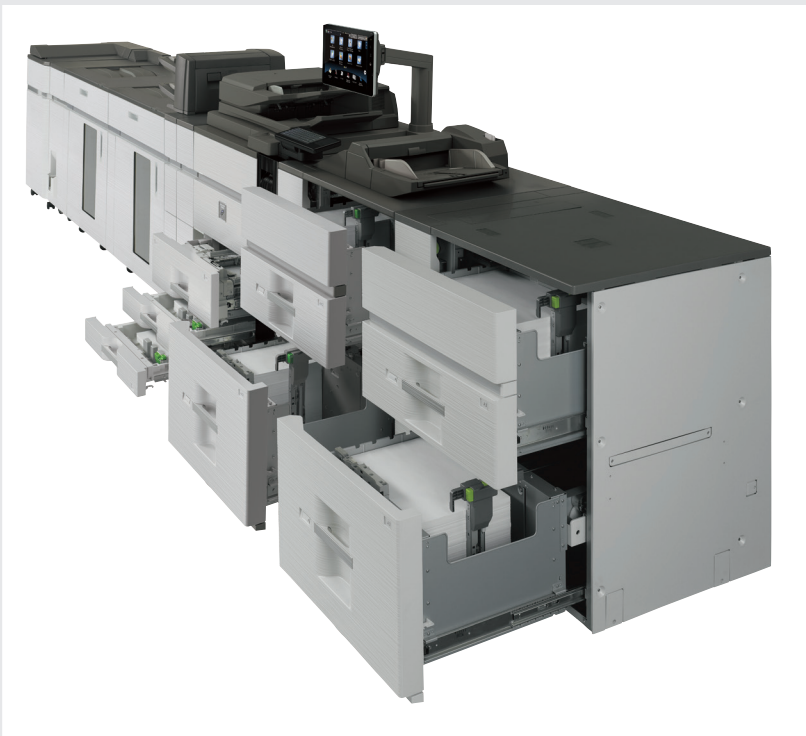

## Some things are too precious to lose /This is Why we conserve and protect.

If your organisation has a formal Environmental Policy – or even if it doesn't and you just want to reduce costs – it makes sense to choose equipment that is kinder to the environment. And that's another key benefit of choosing Sharp.

The resource-saving features of the MX-M1205 and MX-M1055 start even before they are switched on, thanks to biomass plastic. Biomass plastic is derived from renewable biomass sources which not only use fewer irreplaceable resources but also reduce the production of CO<sub>2</sub> during the manufacturing process.

What's more, both printers come with a number of energy-saving features as standard. The scanner is equipped with energy-efficient LED lights for a lower power consumption, for example, and an 'Eco-scan' mode prevents the fuser from being heated when the printer is being used for scan-only jobs.

### Robust security

When you buy an MX-M1205 or MX-M1055 you're investing in some of the industry's toughest security measures, including robust user authentication, PIN printing, a secure network interface, SSL, IPsec, port-based network protection, and IP / MAC address filtering.

We can even prevent the unauthorised copying, scanning, faxing and filing of confidential documents, with our Document Control Function\*. This adds copy-prevention data to a document when it is first copied or printed. If this barely visible data is subsequently detected the printer simply cancels the job or prints a blank page.

If you're concerned about data loss you'll appreciate the optional Data Backup HDD Mirroring Kit, which automatically creates a mirror image of your data on a second hard drive.



\*Requires Data Security Kit option



## Every print room is different /This is Why we give you so many options and upgrades.

All the must have features of the MX-M1205, MX-M1055 are included as standard. But we know that every print room is different and everyone has different needs.

That's why we've put together a range of extra-value production and finishing options so you can configure the printer in just the way you need it.

### Greater versatility

- Fiery Digital Front End print server and Command WorkStation for versatile workflows.
- Web Browsing Expansion Kit for accessing the internet from the touchscreen control panel.
- Choice of trimming units.
- Document inserter.

### Superior cost-efficiency

- Extensive range of finishing options help to save money by tackling more jobs in-house:
  - Multi-folding unit for Z, C, accordion, double and half-folds.
  - Plockmatic inline finishing system for booklet making.
  - 100-sheet staple finisher.
  - Saddle-stitch finisher.
  - Punch-unit; for bound and hole punched documents.

### Enhanced productivity

- Optional A3 large capacity paper feed trays to extend the paper supply to 13,500 sheets for longer uninterrupted printing.
- Stacker and wheeled paper carts to extend the paper capacity to 10,000 sheets.
- Prominent Status Lamp for 'at-a-glance' confirmation of printer status.

### Improved security

- Document Control Function to prevent unauthorised copying.
- Data Backup HDD Mirroring Kit.



## Options & Configuration Examples

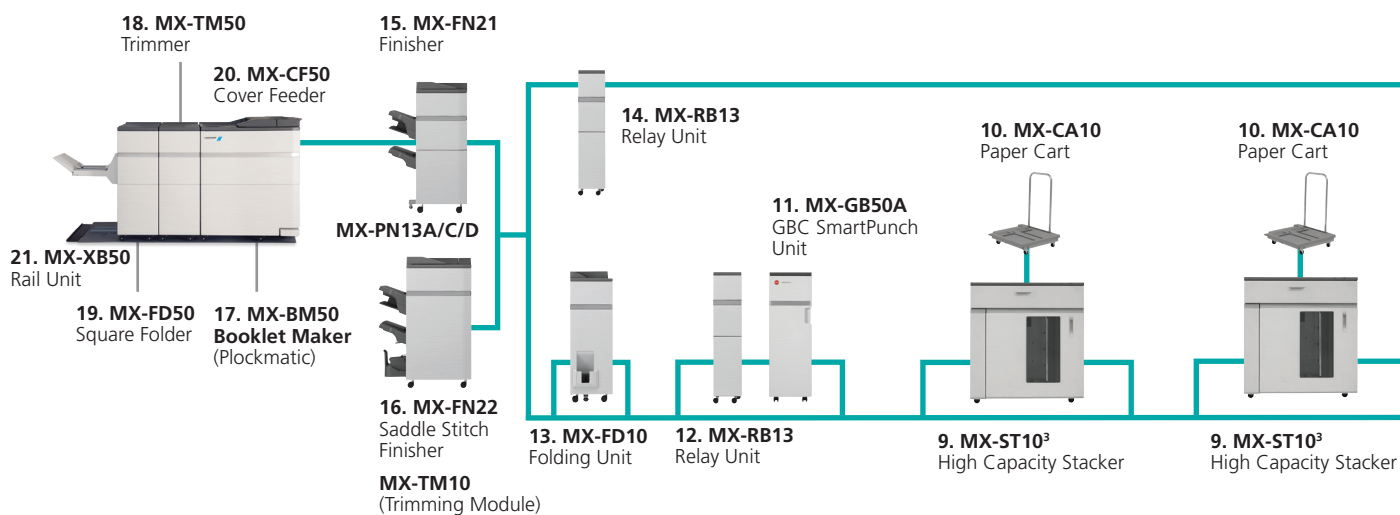

<sup>1</sup> Required if MX-LC13N is installed. <sup>2</sup> Required if 2 x MX-LC13N are installed. <sup>3</sup> Can be end of configuration. <sup>4</sup> Requires MX-RB13 or MX-FD10.

### CONFIGURATION EXAMPLE 1: IDEAL FOR SMALLER PRINT ROOMS



- A4, A3 and A3W paper handling
- 6,700-sheet paper capacity
- 4,000-sheet finisher
- 100-sheet stapling
- 20-sheet booklets
- Inline trimming
- Curl Correction
- Various folding options



## Options & Configuration Examples

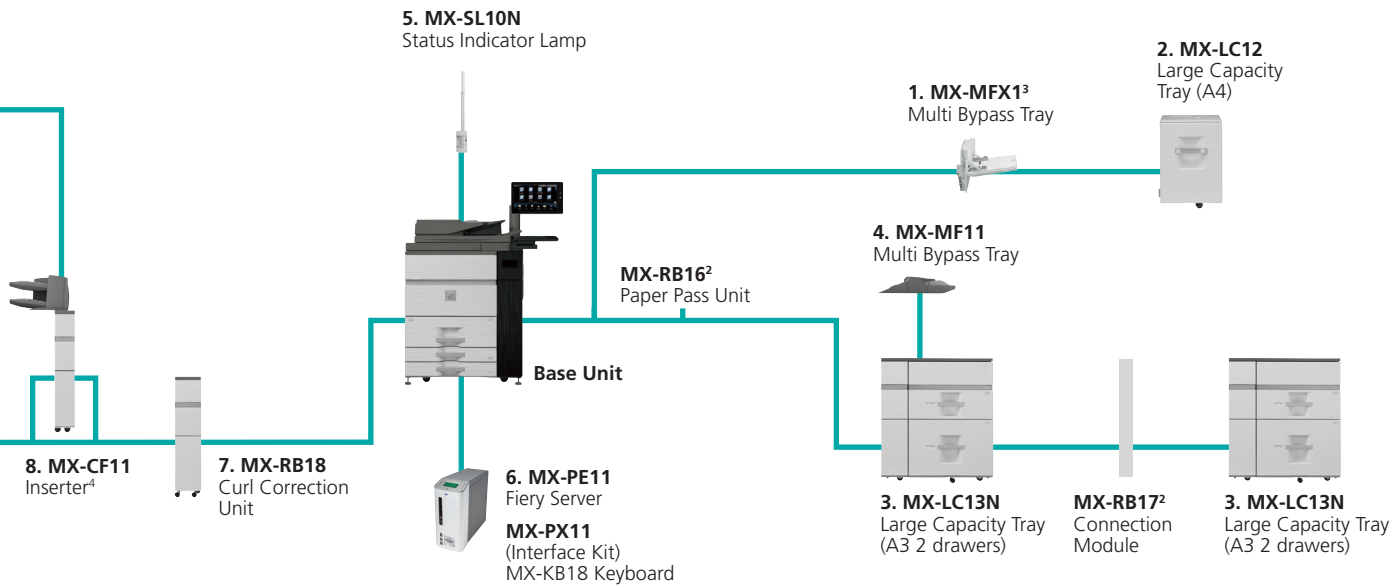

CONFIGURATION  
EXAMPLE 2:  
IDEAL FOR  
LARGER PRINT  
ROOMS



- A4, A3 and SRA3 paper handling
- 13,500-sheet paper capacity
- 4,000-sheet finisher
- 100-sheet stapling
- 20-sheet booklets
- High capacity stackers for 10,000 sheets (plus carts)
- Inline trimming
- Various folding options
- Inserter
- Curl correction
- Fiery digital front end print server

## Base Unit

### MX-KB18 Keyboard

#### 1. MX-MFX1 Multi Bypass Tray

(for main machine)  
A5R-A3W, 100 sheets (80 g/m<sup>2</sup>)  
Can be end of configuration

**2. MX-LC12 Large Capacity Tray (A4)**  
A4-B5, 3,500 sheets (80 g/m<sup>2</sup>)  
Requires MX-MFX1. Cannot be installed with MX-LC13N

**MX-RB16 Paper Pass Unit** (between machine and MX-LC13N)  
Required if MX-LC13N is installed

**3. MX-LC13N Large Capacity Tray**  
(2 drawers)  
A3-A4, 2,500 sheets each (80 g/m<sup>2</sup>)  
Requires MX-RB16. Cannot be installed with MX-LC12.

**MX-RB17 Connection Module**  
Required if 2 x MX-LC13N are installed

**4. MX-MF11 Multi Bypass Tray**  
(for MX-LC13N)  
A3-A5R, 500 sheets (80 g/m<sup>2</sup>)

**5. MX-SL10N Status Indicator lamp**

**6. MX-PE11 Fiery Server**  
Requires MX-PX11 (Interface Kit) and MX-KB18 Keyboard



Keyboard

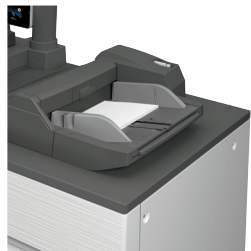

Multi Bypass Tray



Fiery Server

## Finishing

**7. MX-RB18 Curl Correction Unit**  
Corrects paper by putting pressure on the convex/concave curl  
Required if MX-FN21 or MX-FN22 is installed

**8. MX-CF11 Inserter** (200-sheet x 2 bin)  
A3-A5R, 200 sheets each (80 g/m<sup>2</sup>)  
Requires MX-RB18 and either MX-RB13 or MX-FD10

**9. MX-ST10 High Capacity Stacker**  
Paper stacking tray: 5,000 sheets (80 g/m<sup>2</sup>)  
Top tray: 250 sheets (80 g/m<sup>2</sup>)  
Requires MX-RB18 and either MX-RB13 or MX-FD10 if connecting to MX-FN21 or MX-FN22

**10. MX-CA10 Paper Cart**  
Included with MX-ST10 for transport of finished documents.

### 11. MX-GB50A GBC SmartPunch Unit

Paper size A4

Available die sets:  
21 holes, Plastic Comb  
20 holes, Plastic Comb  
47 holes, Color Coil  
23 holes, Wire 2:1/Square  
23 holes, Wire 2:1/Round  
34 holes, Wire 3:1/Square  
34 holes, Wire 3:1/Round  
12 holes, VeloBind  
34 holes, PloClick  
2 holes/Round (8mm pin)  
4 holes/Round (8mm pin)  
2 holes/Round (6.5mm pin)  
4 holes/Round (6.5mm pin)  
4 holes Scandinavian

Custom die sets also available on request  
Requires MX-RB13 and either MX-FN21 or MX-FN22



CombBind®



WireBind



ProClick®



Color Coil®



2 hole



VeloBind®

**12. MX-RB13 Relay Unit** (between 100-sheet finisher and inserter)  
Must be installed if MX-FD10 is not required

**13. MX-FD10 Folding Unit**  
Folding options include Z, C, accordion, double & half folds  
Can only be installed with MX-FN21 or MX-FN22



Folding Unit

**14. MX-RB13 Relay Unit**

**15. MX-FN21 Finisher** (4k - 100-sheet staple)  
A3 - B5 (offset/staple), SRA3 - A5R (non offset)  
Upper tray: 1,500 sheets\*  
Middle tray: 250 sheets\*  
Lower tray: 2,500 sheets\*  
100-sheet\* staple capacity  
(front, rear or 2 point stitching)  
Requires MX-RB18. Cannot be installed with MX-FN22.



Finisher

**16. MX-FN22 Saddle Stitch Finisher**

(4k - 100-sheet staple)  
Requires MX-RB18. Cannot be installed with MX-FN21.  
(4k - 100-sheet staple)  
A3 - B5 (offset/staple), SRA3 - A5R (non offset)  
Upper tray: 1,500 sheets\*  
Middle tray: 250 sheets\*  
Lower tray: 2,500 sheets\*  
100-sheet\* staple capacity  
(front, rear or 2 point stitching)  
Saddle stitch tray: 5 sets (16-20 sheets), 10 sets (11-15 sheets), 15 sets (6-10 sheets), 25 sets (1-5 sheets). Max 20 sheets per set.  
Requires MX-RB18. Cannot be installed with MX-FN21.



Stitch Finisher

**MX-PN13A/C/D Punch Module** (A: 2, C: 2/4 D: 4 wide)  
Requires MX-FN21 or MX-FN22

**MX-TM10 Trimming Module**  
Can only be installed with MX-FN22

**17. MX-BM50 Booklet Maker** (Plockmatic)  
A4, A3, SRA3  
Paper size: 206 x 275 mm (Min) to 320 x 457.2 mm (Max)  
Paper Weight: 64-300 g/m<sup>2</sup>  
Capacity: 1-30 sheets\* (stapled and folded); 1-6 sheets\* (non-stapled and folded)  
Requires MX-FN21

**18. MX-TM50 Trimmer**  
Trim Length: 1-16 mm, Default: 4.5mm  
Requires MX-BM50

**19. MX-FD50 Square Folder** (Plockmatic)  
A4, A3, SRA3  
Paper size: 206 x 275 mm (Min) to 320 x 457.2 mm (Max)  
Paper Weight: 64-300 g/m<sup>2</sup>  
Capacity: 1-30 sheets\* (stapled and folded)  
Requires MX-BM50 & MX-TM50

**20. MX-CF50 Cover Feeder** (Plockmatic)  
Requires MX-BM50

**21. MX-XB50 Rail Unit** (Plockmatic)  
Requires MX-BM50

\* A4 or smaller, 80 g/m<sup>2</sup>.



## Faxing

MX-FWX1 Internet-Fax Expansion Kit  
MX-FX11 Fax Expansion Kit

## Printing, Connectivity & Security

MX-PF10 Barcode Font Kit  
MX-PUX1 XPS Expansion Kit  
MX-AM10 Web Browsing Expansion Kit  
AR-SU1 Stamp Unit  
MX-EB11 Enhanced Compression Kit  
MX-AMX1 Application Integration Module  
MX-FR53U Data Security Kit (commercial version)  
MX-EB15HDD Mirroring Kit

## Scanning

AR-SU1 Stamp Unit  
Marks already scanned documents for checking.  
MX-EB11 Enhanced Compression Kit  
Enables creation of high compression PDFs.

## Sharpdesk Licenses

MX-USX1/X5/10/50/A0  
1/5/10/50/100-License Kit

## Sharp OSA®

MX-AMX1 Application Integration Module  
MX-AMX2 Application Communication Module  
MX-AMX3 External Account Module

WIDE RANGE OF OPTIONS FOR  
PROFESSIONAL PRINT ROOMS



# Specifications

## General

<b>A4 Engine speed</b> (ppm/cpm) (Max)	<b>A4</b>	<b>A3</b>
MX-M1205	120	54
MX-M1055	105	52

<b>Base Unit Paper size</b> (Min-Max)	<b>A4</b>
Drawer 1 & 2	A4
Drawer 3	A4R - A3W
Drawer 4	A5R - A3W
Multi bypass	A5R - A3W

<b>Base Unit Paper weight</b> (g/m <sup>2</sup> )	
Drawer 1 & 2	60 - 105
Drawer 3 & 4	60 - 220
Multi bypass	52 - 300

<b>LCT Paper capacity</b> (Std - Max)	
Sheets	3,100 - 13,500
Drawers	4 - 8 (plus multi bypass tray)

<b>Warm-up time</b> *1 (seconds)	210 or less
----------------------------------	-------------

<b>Duplex</b>	Standard
---------------	----------

<b>Memory</b>	
Copier/Printer (shared)	5 GB
HDD	1 TB

<b>Power requirements</b>	Rated local AC voltage $\pm$ 10%, 50/60 Hz
---------------------------	--

<b>Power consumption</b> (kW) (Max)	
MX-M1205	2.99
MX-M1055	2.99

<b>Dimensions</b> (mm) (W x D x H)	1,099 x 775 x 1,529
------------------------------------	---------------------

<b>Weight</b> (kg)	300
--------------------	-----

## Copier

<b>Original paper size</b> (Max)	A3
----------------------------------	----

<b>First copy time</b> *2 (seconds)	
MX-M1205	3.2
MX-M1055	3.2

<b>Continuous copies</b> (Max)	9,999
--------------------------------	-------

<b>Resolution</b> (dpi)	1200 x 1200, 600 x 600
-------------------------	------------------------

<b>Halftone gradation levels</b>	256
----------------------------------	-----

<b>Zoom range</b> (%)	25 - 400 (25 - 200 using DSPF) in 1% increments
-----------------------	---

<b>Presnet copy ratios</b>	10 (5R/5E)
----------------------------	------------

## Scanning

<b>Scan method</b>	Push scan (via operation panel) Pull scan (TWAIN-compliant application)
--------------------	--

<b>Resolution</b> (dpi)	
Push scan	100, 150, 200, 300, 400, 600
Pull scan	75, 100, 150, 200, 300, 400, 600 50 - 9,600 via user setting

<b>File formats</b>	Scan to e-mail, desktop, FTP server, network folder (SMB), USB memory, fax*6, i-fax*7
---------------------	--

<b>Scan destinations</b>	Scan to e-mail, FTP server, network folder (SMB), USB memory
--------------------------	--

<b>Scanner utilities</b>	Sharpdesk, Sharpdesk Mobile, Sharp Network Scanner Tool, Sharp OSA Network Scanner Tool*8
--------------------------	--

## Network Printer

<b>Resolution</b> (dpi)	1200 x 1200, 600 x 600
-------------------------	------------------------

<b>Interface</b>	USB2.0, 10Base-T / 100Base-TX / 1000Base-T
------------------	--

<b>Supported OS</b>	Windows Server® 2008 / x64, Windows Vista® / x64, Windows® 7 / x64, Windows® 8 / x64, Windows® 8.1 / x64, Windows Server® 2012 x64, Windows 10 / x64. Mac OS X 10.4, 10.5, 10.6, 10.7, 10.8, 10.9, 10.10
---------------------	--

<b>Network protocols</b>	TCP/IP (IPv4 & IPv6), IPX/SPX (Netware), EtherTalk (AppleTalk)
--------------------------	--

<b>Printing protocols</b>	LPR, Raw TCP (port 9100), POP3 (e-mail printing), HTTP, Novell Printserver application with NDS and Bindery, FTP for downloading print files, EtherTalk printing, IPP
---------------------------	---

<b>PDL</b>	Std PCL6, Adobe® PostScript® 3™ Opt XPS*3
------------	--

<b>Available fonts</b>	
PCL	80
Genuine Adobe® PostScript® 3™	136

## Document Filing

<b>Document filing capacity</b> (pages/or files)	
Main folder & Custom Folder	35,000*6 or 5,000
Quick file folder	10,000*6 or 1,000

<b>Stored jobs</b>	Copy, print, scan, fax transmission*6
--------------------	---------------------------------------

<b>Storage folders</b>	Quick folder, main folder, custom folder (max.1,000)
------------------------	--

<b>Confidential storage</b>	Password protection
-----------------------------	---------------------

## Fiery MX-PE11 DFE Print Server

<b>Server type</b>	External Server
--------------------	-----------------

<b>System software</b>	Fiery FS200 Pro
------------------------	-----------------

<b>CPU type</b>	Intel® Pentium® Processor G1820 2.7 GHz
-----------------	---

<b>Memory</b>	4 GB RAM / 500GB HDD
---------------	----------------------

<b>Supported OS</b>	Windows Server® 2008, Windows Server® 2008 R2, Windows Server® 2012, Windows Server® 2012 R2, Windows Vista®, Windows® 7, Windows® 8, Windows® 8.1, Windows® 10, Mac OS X 10.7, 10.8, 10.9, 10.10
---------------------	---

<b>Interface</b>	Gigabit Ethernet
------------------	------------------

<b>Power source</b>	100-240 VAC, 50/60 Hz, 3A
---------------------	---------------------------

<b>Power consumption</b>	45w (Typical)/180w (Max.)
--------------------------	---------------------------

<b>Dimensions approx.</b> (mm) (W x D x H)	140 x 394 x 318
---	-----------------

<b>Weight approx.</b>	6.8kg
-----------------------	-------

## Notes

\*1 At rated voltage. May vary depending on machine conditions and operating environment. \*2 Best achieved time based on A4 copy, long-edge feeding from 1st paper drawer, using document glass, when machine is ready. May vary depending on machine conditions and operating environment. \*3 Requires optional MX-PUX1. \*4 To view XPS files on PCs not running Windows Vista, you must have the XPS View application installed. \*5 Requires optional MX-EB11. \*6 Measured using Sharp's standard chart (A4 with 6% coverage, B/W). Storage capacity will vary depending on the type of document and the scan settings.

Design and specifications are subject to change without prior notice. All information was correct at time of print. The ENERGY STAR logo is a certification mark and may only be used to certify specific products that have been determined to meet the ENERGY STAR programme requirements. ENERGY STAR is a US registered mark. Windows, Windows XP, Windows Server and Windows Vista are registered trademarks of Microsoft Corporation. All other company names, product names, and logotypes are trademarks or registered trademarks of their respective owners. ©Sharp Corporation April 2016 Job: (17170). Ref: Brochure MX-M1205/MX-M1055. All trademarks acknowledged. E&OE.

June 2016 Edition



Inspiring ideas from technology

[www.sharp.co.uk](http://www.sharp.co.uk)

SHARP BUSINESS SYSTEMS UK PLC  
4 FURZEGROUND WAY  
STOCKLEY PARK  
UXBRIDGE  
MIDDLESEX UB11 1EZ  
TEL: +44 (0)20 8734 2000

DEALER STAMP